

Ground Mount systems

Aluminum Ground Mount for PV Module Ground systems

Horizontal Ground Mounting System Component

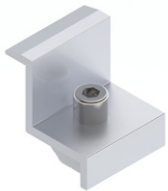
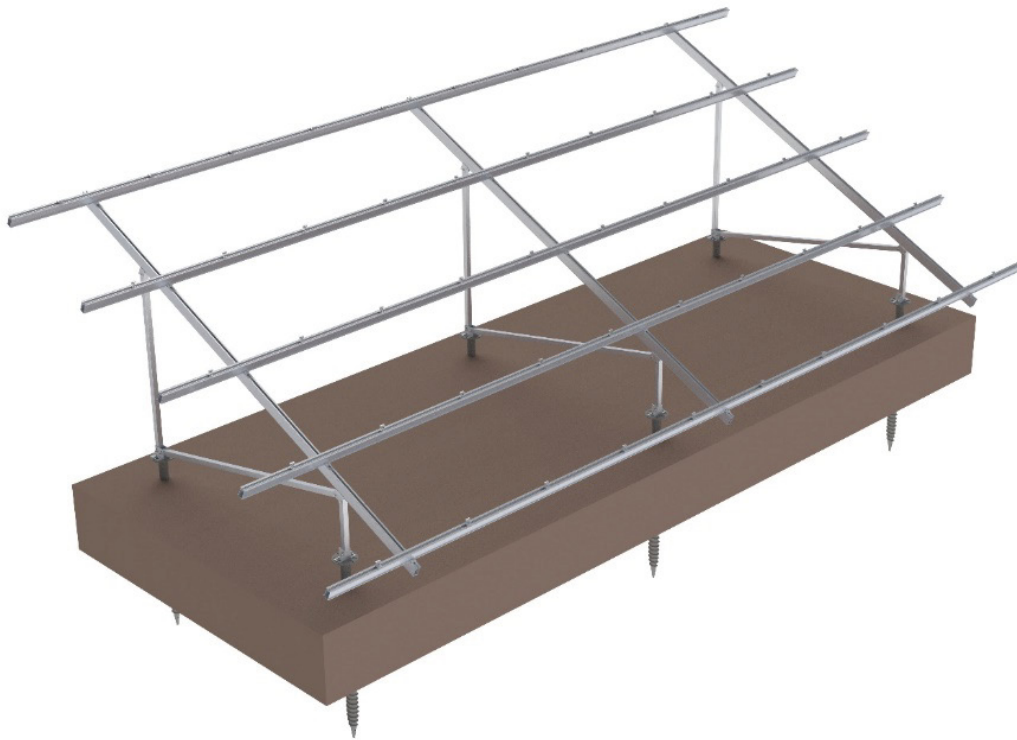

1.ERK-GEC-XX

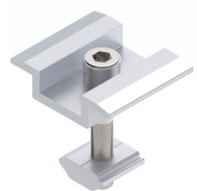

2.ERK-GIC-XX

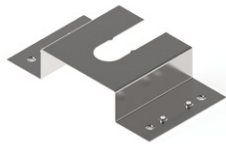

3.ERK-GEL



4.ERK-ELG



5.ERK-R80



6.ERK-SFR-R80



7.ERK-GRC

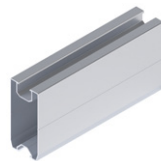

8.ERK-B95



9.ERK-GS2



10. ERK-CH2-01



11. ERK-CH2-02



12. ERK-GB2-01



13. ERK-GB2-02



14.ERK-GF1-1600

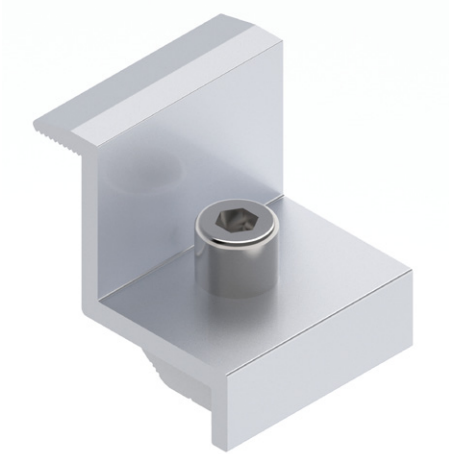
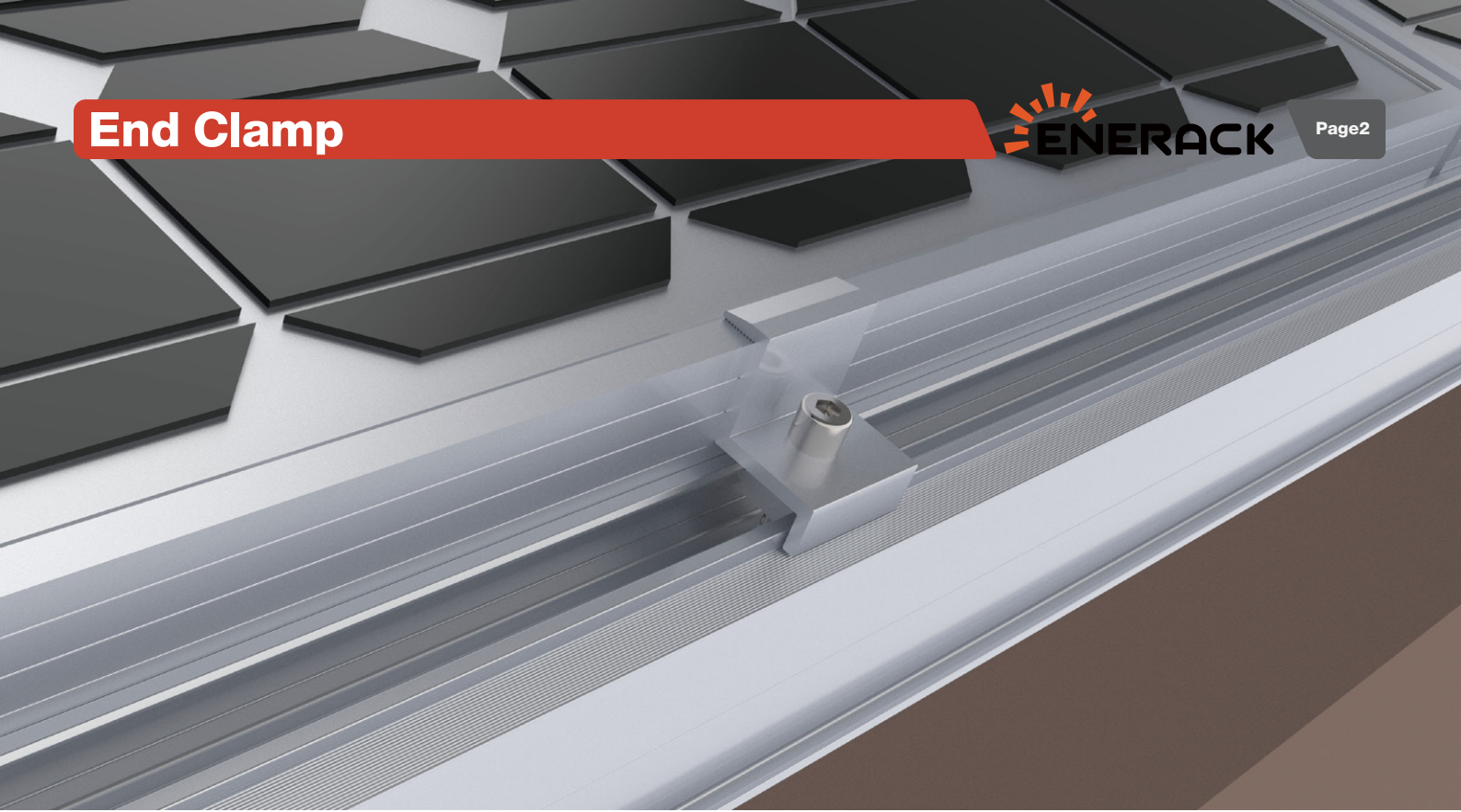

End Clamp

ERK-GEC-XX End clamp is suitable for horizontal ground mounting system, with different height end clamp can correspond to different thicknesses solar panel.

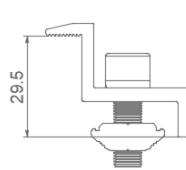
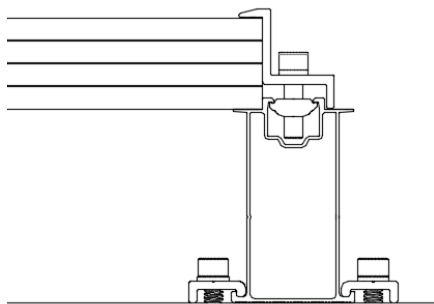

ERK-GEC-30

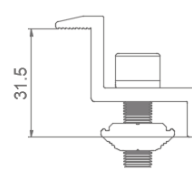

ERK-GEC-32

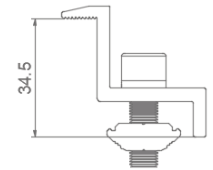

ERK-GEC-35

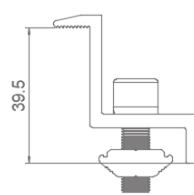

ERK-GEC-40

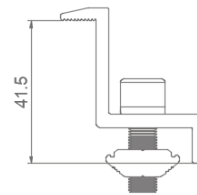

ERK-GEC-42

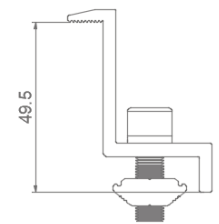

ERK-GEC-50

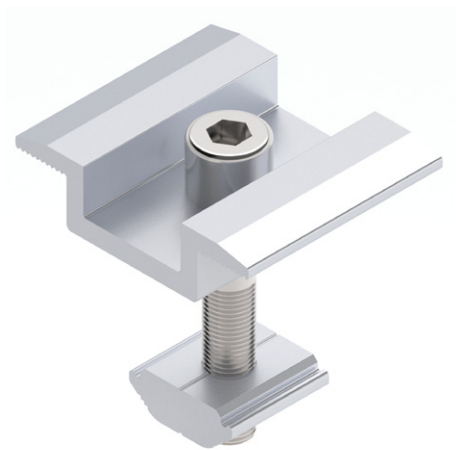
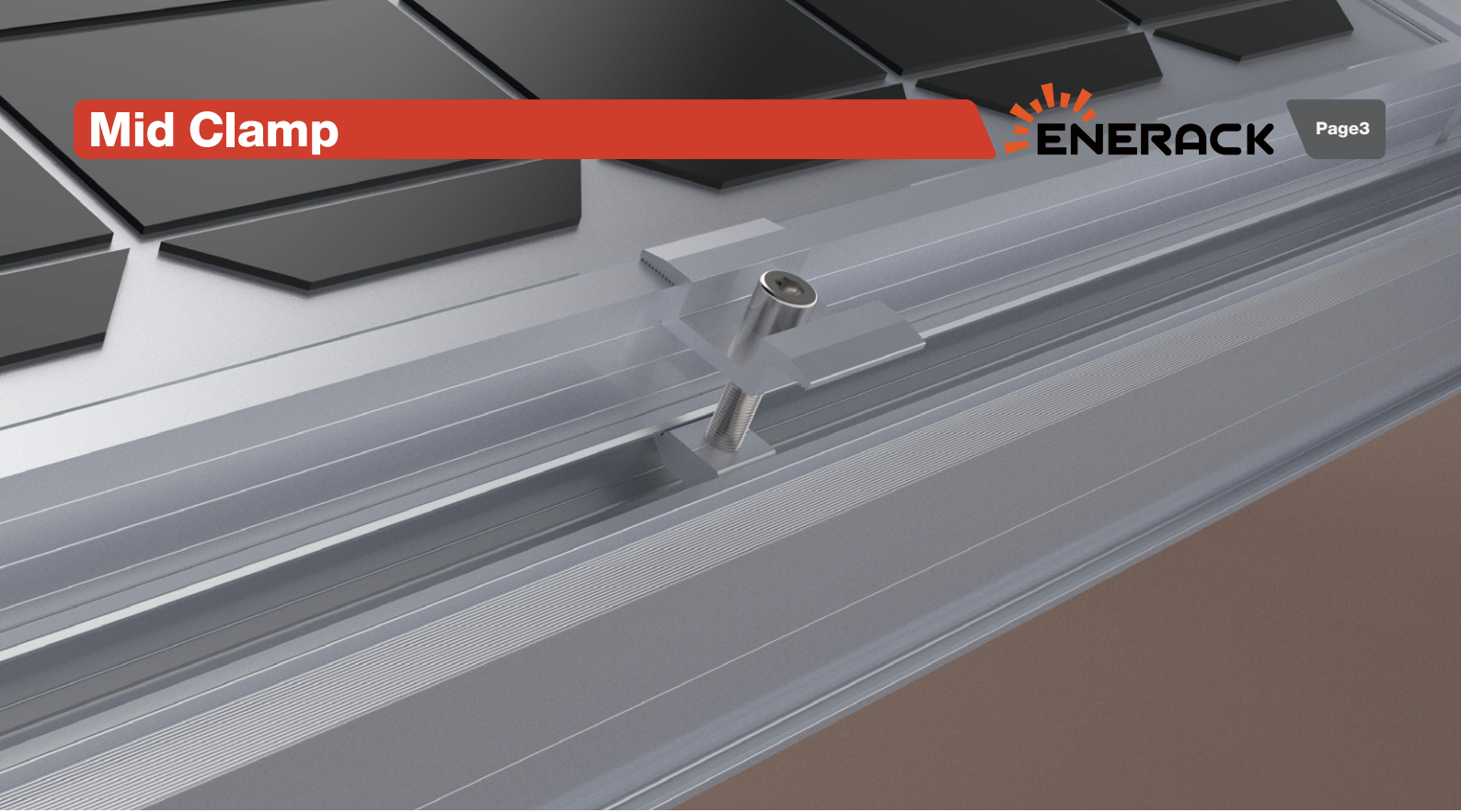

Mid Clamp

ERK-GIC-XX Mid clamp suitable for horizontal ground mounting system, with different height mid clamp can correspond to different thicknesses solar panel.

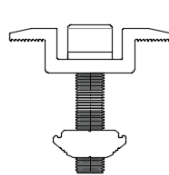
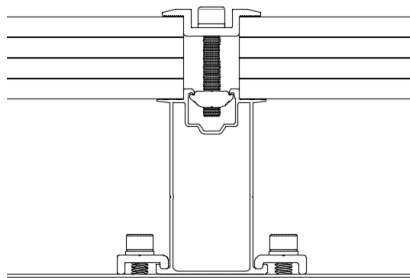

ERK-GEC-30

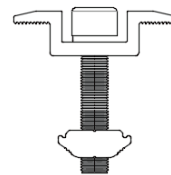

ERK-GEC-32

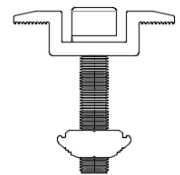

ERK-GEC-35

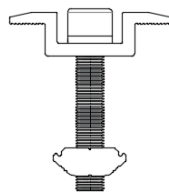

ERK-GEC-40

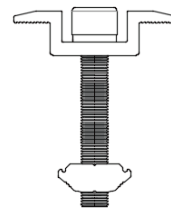

ERK-GEC-42

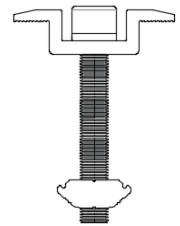

ERK-GEC-50

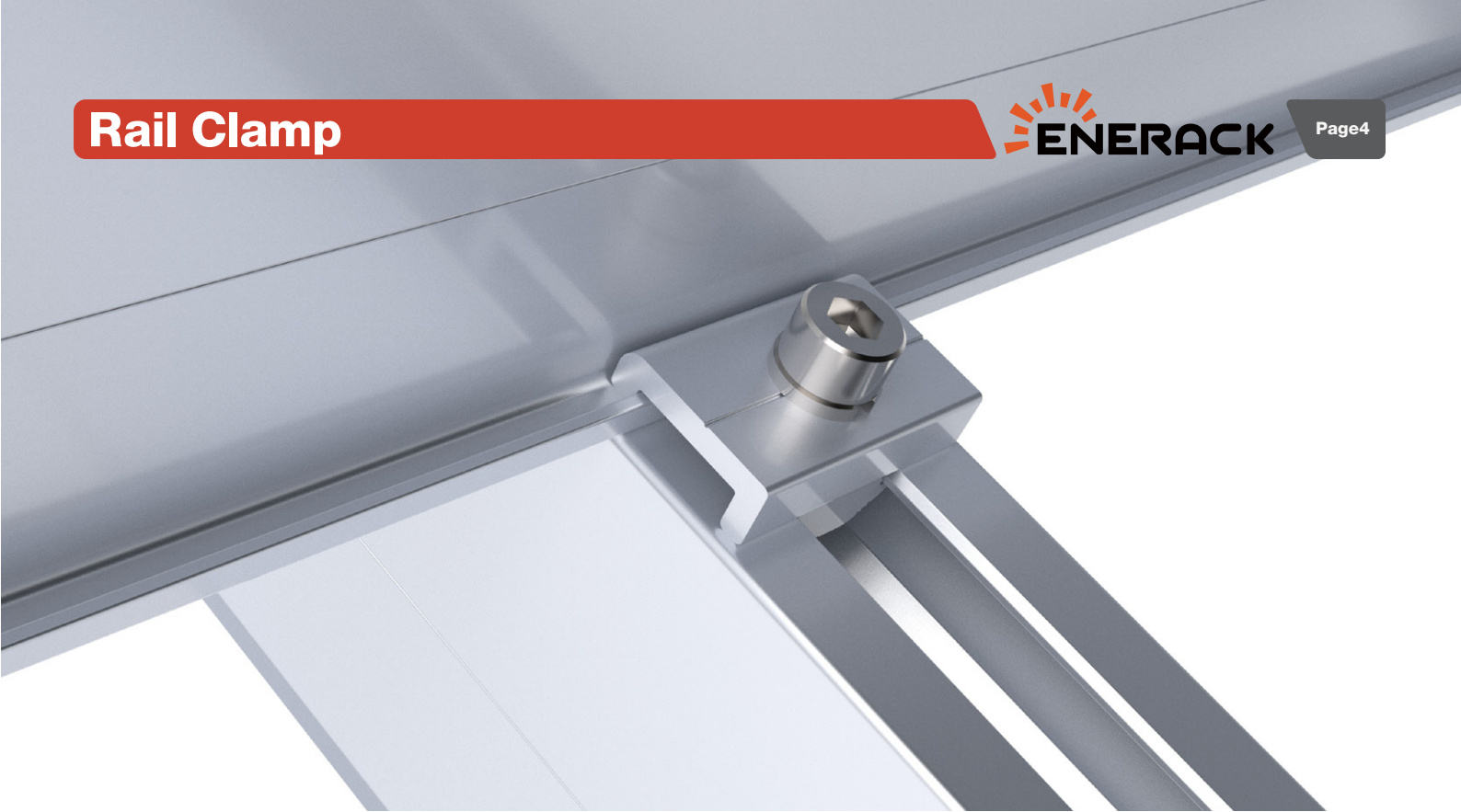

Rail Clamp

Main Force Component: Rail

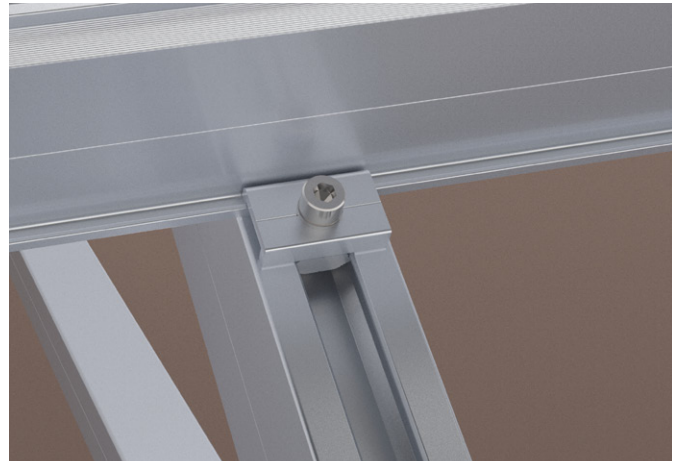
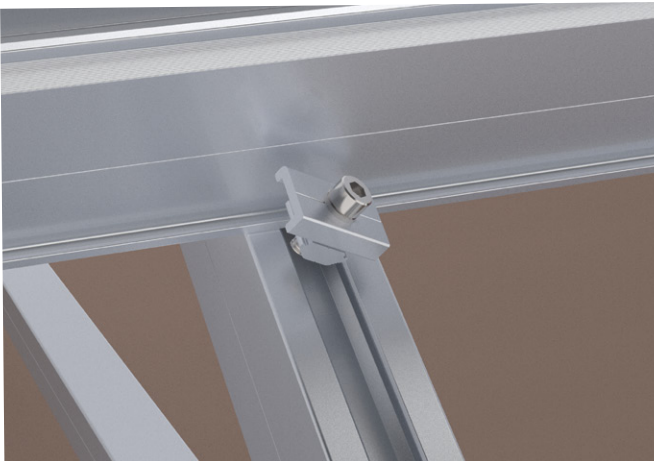
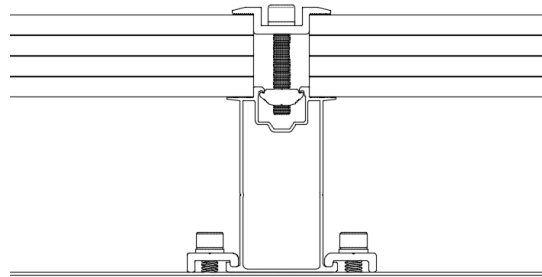
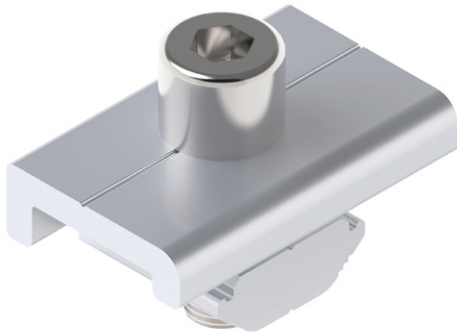

ERK-R80

Main Force Component: MAIN BEAM Rail

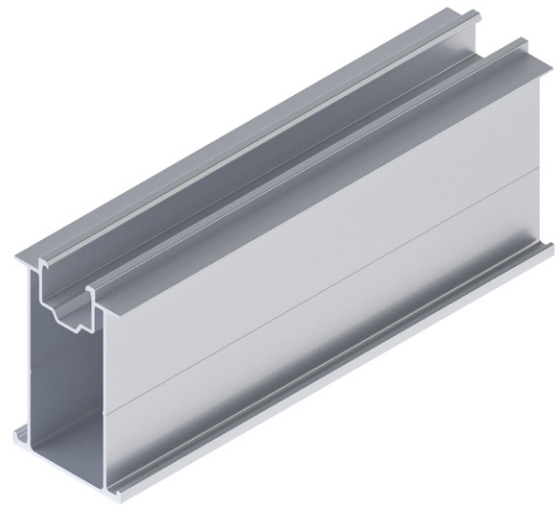

Dimensions in mm

Mechanical Properties

Material	Aluminum 6005 T5
Finish	Natural Anodized
Ultimate Tensile Strength	260Mpa
Yield Strength	240MPa

Section Properties

Section area moment	S3=372396.63mm ³ S2=112935.28mm ³
Cross section modulus	W3(MIN)= 8974.26mm ⁴ W2(MIN)= 4517.41mm ⁴

Dimensions in mm

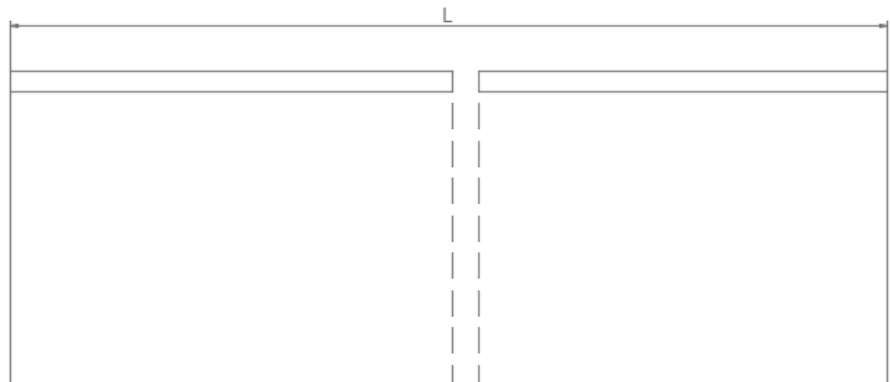
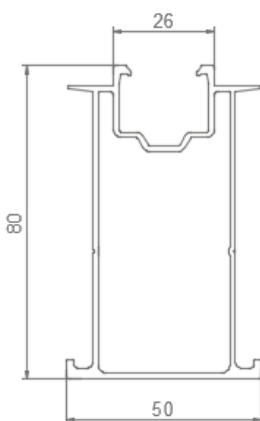

ERK-B95

Main Force Component: Main beam

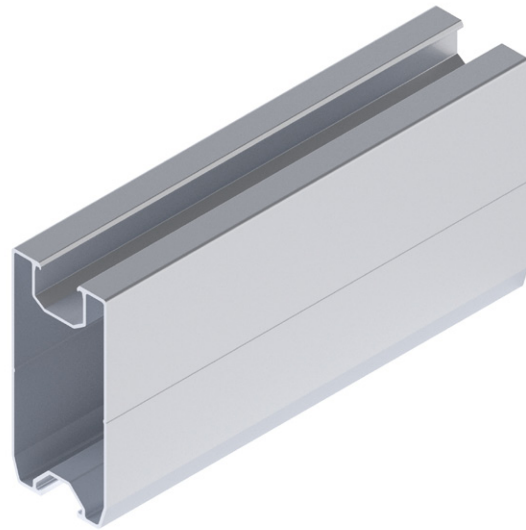

Dimensions in mm

Mechanical Properties

Material	Aluminum 6005 T5
Finish	Natural Anodized
Ultimate Tensile Strength	260Mpa
Yield Strength	240MPa

Section Properties

Section area moment	S3= 514707.76mm ³ S2= 141822.53mm ³
Cross section modulus	W3(MIN)= 10570.55mm ⁴ W2(MIN)= 6303.22mm ⁴

Dimensions in mm

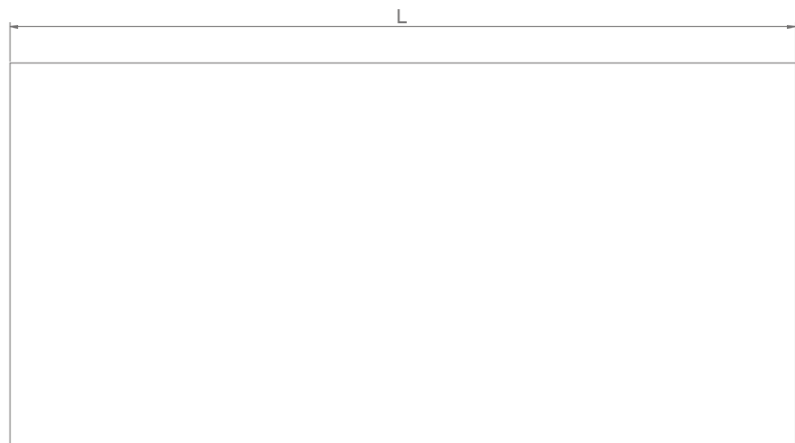
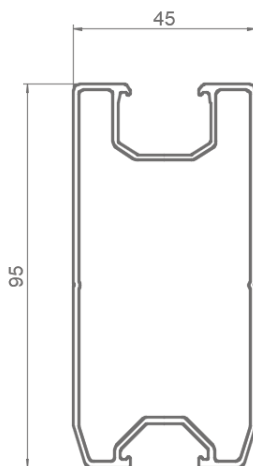

ERK-GS2

Main Force Component: Column



Dimensions in mm

Mechanical Properties

Material	Aluminum 6005 T5
Finish	Natural Anodized
Ultimate Tensile Strength	260Mpa
Yield Strength	240MPa

Section Properties

Section area moment	S3= 81372.88mm ³ S2= 94534.66mm ³
Cross section modulus	W3(MIN)= 3616.57mm ⁴ W2(MIN)= 4201.54mm ⁴

Dimensions in mm

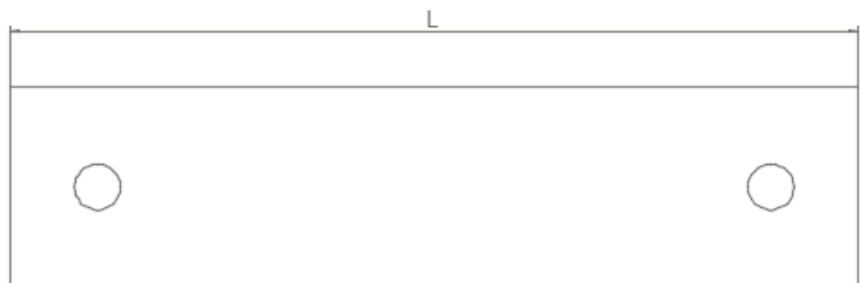
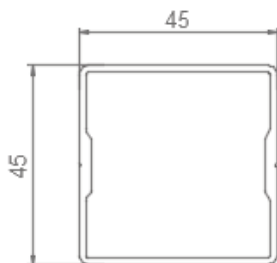

ERK-SFR-R80

Use rail connector with self-tapping screws to connect rails.



Dimensions in mm

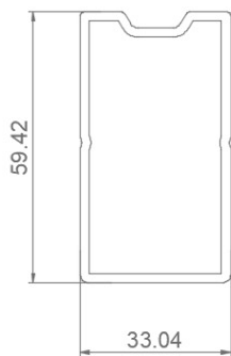

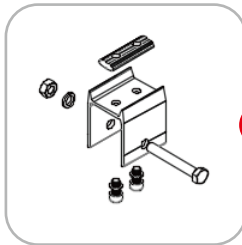
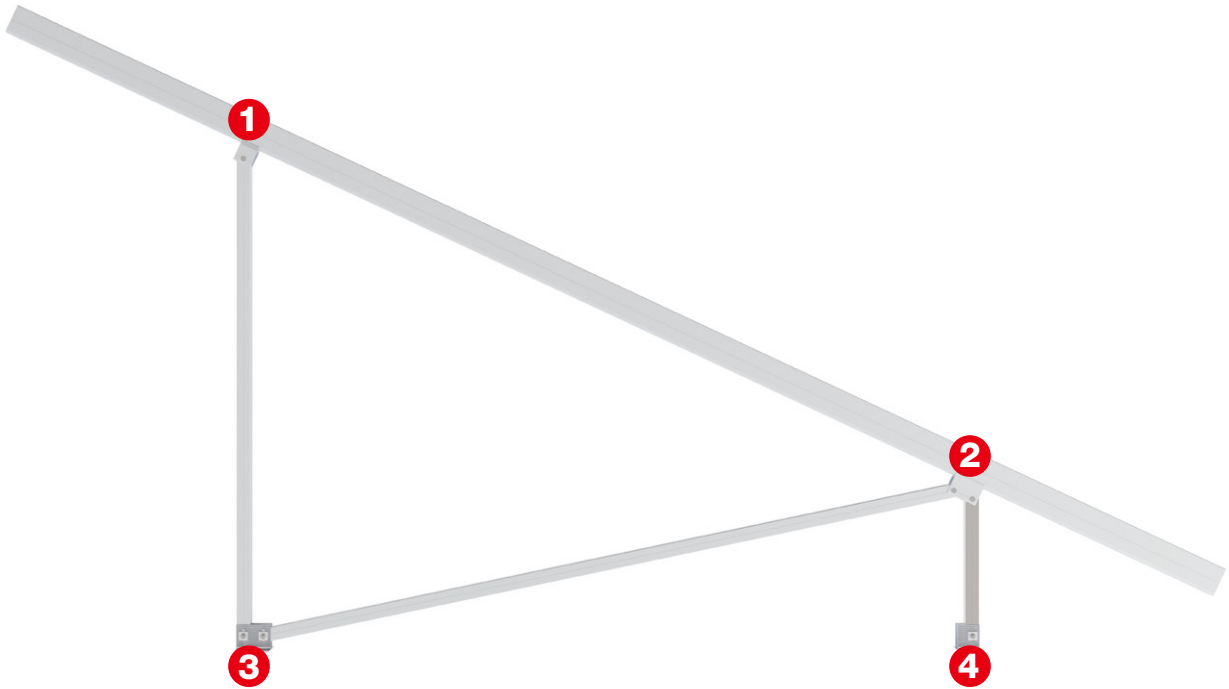

1

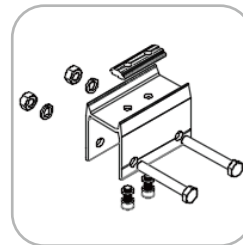

2

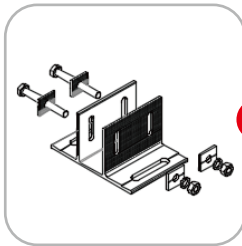

3

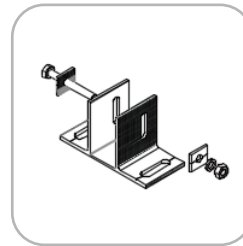
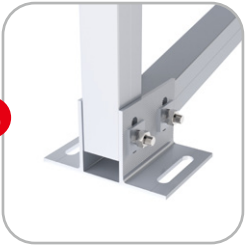

4

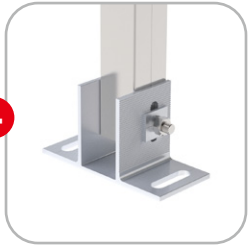

Ground mounting system has been maximize pre-assembly before shipment, which make it install more convenient.

Depending on the different design conditions, pre-assembly support are generally designed into the following two shapes:

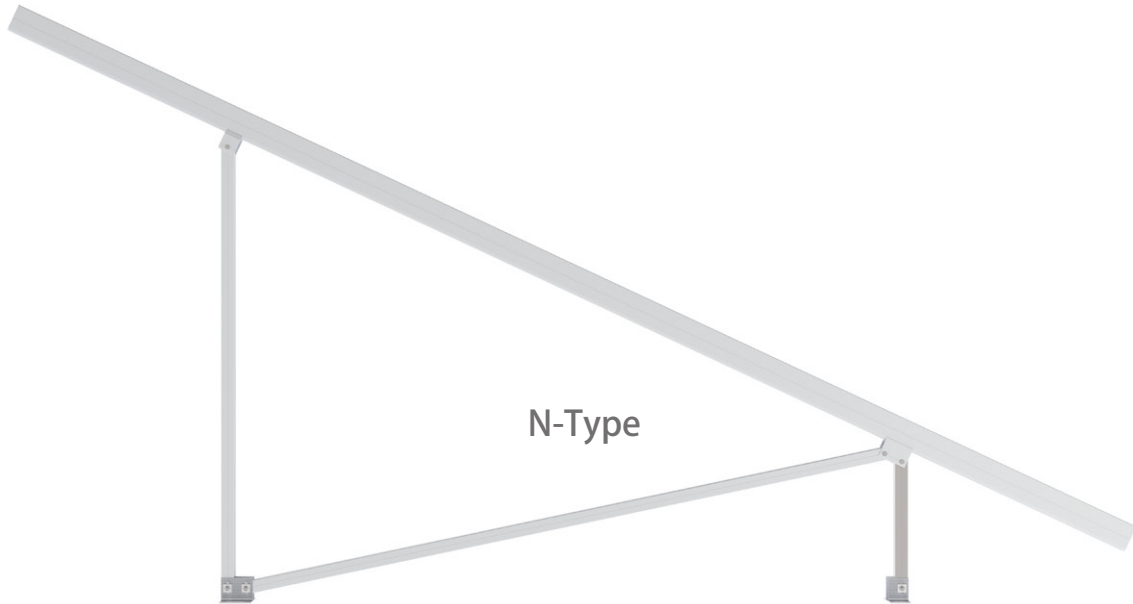

The N-Type pre-assembly support is mainly used for the small wind & snow load condition projects.(2-4 columns)

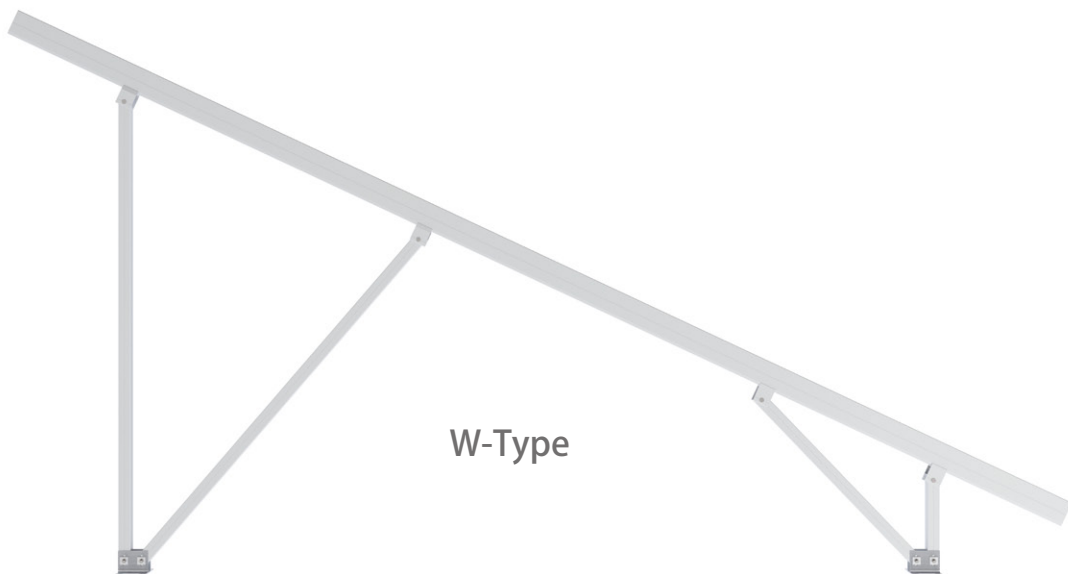

The W-type pre-assembly Support is mainly for the 4-5 columns wind & snow load condition projects.
We will add cross support to make the structure stronger if the ground height is higher or wind & snow load is larger.

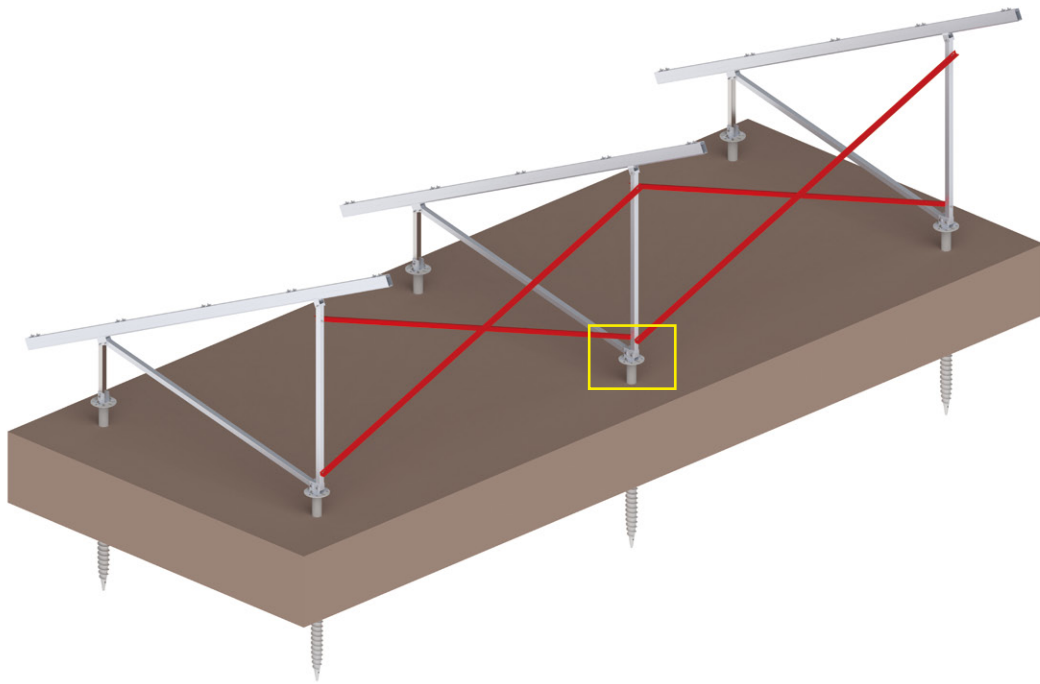

Ground mounting system are commonly used for
Concrete Foundation and Screw Foundation.



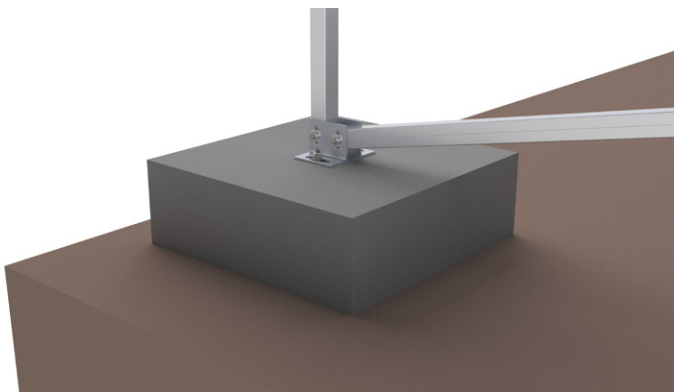

Concrete Foundation

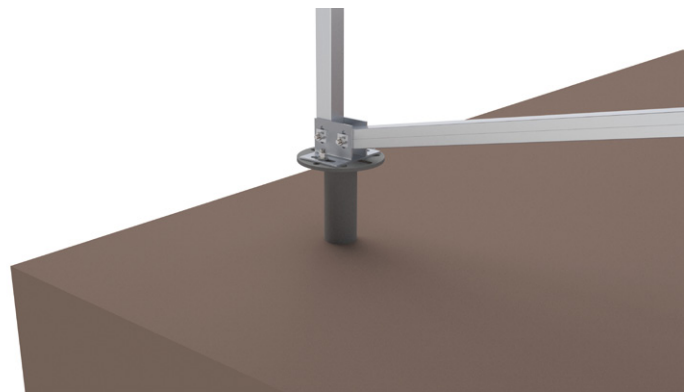

Screw Foundation

Customers can choose different foundations according to their needs.
The following table is a comparison of the two foundations:

Item	Concrete Foundation	Screw Foundation
Applicable terrain	Flat, Even Tilt, Ladder	
Applicable geology (reference)	Random	SWS3 ≤ N ≤ 10 SWS Test, cohesive soil 3 ≤ N ≤ 10
Difficult or Easy Degree	Complicated	Easy
Cost	Higher	Lower
Adjustment range	Not convenient to adjust the height of base	Larger
Corrosion resistance	Anti-Corrosion	Hot-dip galvanizing on the surface of the screw foundation, which has met the anti-corrosion requirements of the service life

Conventional pile compression and tensile strength reference values(KN)

Grounds crew Length	N=3		N=5		N=7		N=10	
	Resistance	compression Resistance	Resistance	compression Resistance	Resistance	compression Resistance	Resistance	compression Resistance
1600	8.7	9.1	14.6	15.2	20.4	21.4	29.2	30.6
1800	9.9	10.2	16.5	17.1	23.1	24	33	34.4
2000	11	11.4	18.4	19	25.8	26.7	36.8	38.2
2200	12.2	12.5	20.3	21	28.4	29.4	40.6	42
2500	13.9	14.2	23.2	23.8	32.4	33.4	46.4	47.8

Remarks: The N value of the soil in this table are based on the Swedish penetration test (SWS).



Tel: +86 - 592-5669285
Fax: +86 - 592-5669235
Mail: info@enerack.com
web: www.enerack.com
Add: 203A, Norinco Business Plaza, NO.6
Huli Avenue, Huli District, Xiamen, China